

Au Bon Panel: Baking Your Own Adaptive Components and Panels with Autodesk® Revit® Architecture

Robert Manna – Burt Hill
Zach Kron – Autodesk

Lab Assistants:

Steve Stafford – AEC Advantage
Simon Whitbread – Beca Corporate Holdings Ltd.
David Light – HOK

AB316-1L / AB330-5L

This class builds on the topics covered in "Parametrics Laid Bare: Panels and Adaptive Components in Autodesk Revit". To make effective adaptive panels, trusses, columns, pseudo-stairs, louvers, and assorted widgets—users need a solid foundation in techniques for building parametrically driven families in the Core Modeling environment. This toolset offers an enormous amount of flexibility, but requires a distinctly new Revit approach to the construction of these families. The attendee will learn the fundamental skills necessary to build Panel By Point and Adaptive Component families. The class will focus on understanding and diagnosing the behavior of these families, and best practices for creating predictable behavior. Attendees will be exposed to the use of a Divided Surface as an array tool and how to apply Reporting Parameters to get information out of their models. At the end of this lab, the attendee should be ready to directly execute the topics introduced in the lecture.

About the Speakers:

Robert graduated from RPI in 2003 with a B. Arch. and B.S. in Building Sciences. Since then he has worked for Burt Hill in Philadelphia and Boston. He was a team member on four major projects, including a 450 bed dormitory, a multi-use development project and two university classroom/lab buildings. He is an integral part of the team planning and implementing Burt Hill's transition to a fully coordinated BIM process. Robert teaches internally, develops curriculum and helps to develop long term goals and plans for the use of BIM and represents Burt Hill on the AIA LFRT BIM committee. His daily activities include the development and continuing implementation of tools, specialty project team assistance/participation and content development. He has been a guest lecturer at the BAC, taught previously at AU and presented at BIM events hosted by the AIA, ACEC, Autodesk and CAD vendors. He has written two articles about Autodesk® Revit® for the AUGI® *AEC Edge*. He also maintains a personal blog dedicated to Revit and BIM.

Zach is a software analyst with the Simulation team at Autodesk, currently working on emerging products. Since 2007 he has been closely involved in the development of visualization and modeling capabilities in Revit, including the recent conceptual design enhancements developed for release 2010

and 2011. He and fellow team members from Autodesk recently presented on the modeling tools and the recently released CEA tools at Acadia 2010. In his spare time he maintains a personal blog on parametric modeling and design. Before joining Autodesk in 2007, he worked for design firms in the Boston area on projects ranging from furniture to highways and bridges. Zach holds a B.A. in Fine Art, Sociology and Anthropology from Swarthmore College, and a Masters of Architecture from MIT.

David Light is currently employed as the Revit/BIM Specialist for HOK London, focusing on Revit and BIM as well as helping to drive forward the HOK's global BuildingSMART principles. David started out his working career as an architectural technician, where he learnt the skill of drafting on the drawing board and construction detailing. Realizing that CAD was the future, he transitioned to Microstation and then onto AutoCAD and 3dsMax. David was first introduced to Revit at version 4.5, just after the Autodesk acquisition and has had an unhealthy passion for the technology ever since. Before joining HOK; David worked for an the UK's Autodesk Premier Solutions Centre providing coaching, training and consultancy in Revit Architecture and Revit Structure. David has developed a reputation as one of the leading UK experts in Revit and is a popular speaker and blogger on all things Revit and BIM.

Steve has been a returning speaker at Autodesk University since 2004 as well as the Australian Revit Technology Conference in 2006 and 2009 (RTC). He started using Autodesk® Revit® in 2002. He is a well-established Revit consultant and is currently the CEO of his firm AEC Advantage, Inc. Very active in the Revit community at large, he was an early member of the Revit community forum at Zoogdesign, and he now serves as the forum manager for the Autodesk User Group International (AUGI®) Revit Community as well as serving on the AUGI® board of directors from 2006-2008. He created, writes, and manages three Revit blogs: www.Revitoped.com, www.revitinside.com, and www.revitjobs.com. He currently lives in Southern California with his wife and two children.

Originally from London, Simon relocated to Auckland in 2002. Simon has over 25 years experience in the building services and architectural industries. Since the early 1990s he has been involved in developing and managing CAD and IT Systems for various companies. After a 5-year term with one of New Zealand's leading architects, where he led the implementation of Revit® Architecture, he spent some time with an Autodesk® reseller, providing training for all levels in Revit Architecture and MEP. Using Revit since R5.1, he is now a Revit specialist for a multinational, multi-service company providing implementation, training, and support.

robert.manna@burthill.com / dorevit.blogspot.com / zachary.kron@gmail.com / buildz.blogspot.com / david.light@hok.com / autodesk-revit.blogspot.com / steve@aecadvantage.com / www.revitoped.com

Introduction

This lab builds on the topics covered in "Parametrics Laid Bare: Panels and Adaptive Components in Autodesk Revit". To make effective adaptive panels, trusses, columns, pseudo-stairs, louvers, and assorted widgets—users need a solid foundation in techniques for building parametrically driven families in the Core Modeling environment. This toolset offers an enormous amount of flexibility, but requires a distinctly new Revit approach to the construction of these families. The attendee will learn the fundamental skills necessary to build Panel By Point and Adaptive Component families. The class will focus on understanding and diagnosing the behavior of these families, and best practices for creating predictable behavior. Attendees will be exposed to the use of a Divided Surface as an array tool and how to apply Reporting Parameters to get information out of their models. At the end of this lab, the attendee should be ready to directly execute the topics introduced in the lecture.

How to read this document:

First, after this introductory section we have some vocabulary, this list includes [links](#) to various web sources that will give you even more background on the topic. Important **Terms** or **Keywords** will be highlighted with bold text. The exercises start numbered with Roman Numerals:

- I. **We've written three exercises** - in some cases we include extra material that may not be covered in class (we only have sixty minutes!!!). Within each exercise the primary text is the numbered steps:

- 1) Steps give instructions for how to complete each exercise; generally we give explicit instructions on what to do, or how to do something in Revit. We also assume that you are familiar with Revit, its common terms and vocabulary, as well as the general Revit UI. For instance if we say "label a dimension string" we hope that such a concept is not new to you, and in fact is second nature. Sometimes after a specific step there might be a:

Note: notes are here to help you better understand the concept the step is supposed to relate to you. Sometimes we think the concepts may not be as obvious as others, so when you take this document home, the notes will hopefully convey some of the stuff that we're going to talk about in person. Last we also sometimes include a:

Key Concept – these are the real "nuggets" you took our lab to learn about. It is one of the major ideas that we're trying to convey with the exercise we are doing, and hopefully is something that you may not have learned or known very easily on your own.

Vocabulary

Armature – a framework around which a sculpture is built. In the case of this lab armature is primitive geometry that has a divided surface which is representative of a “building” (or some element of a building or geometry in a project). For the purposes of this class armature(s) are used as a host for Curtain Panels by Pattern or Adaptive Component families.

Rig – a term borrowed from the animation and game industry, rig refers to creating a parametric skeleton that geometry is attached to so that the geometry flexes based on the motion of the skeletal rig. In the case of this class rig is what will be constructed in the panel or adaptive component families.

Adaptive Component (AC) – a type of family in Revit. Adaptive Components can be assigned to multiple categories, currently they can only be placed (hosted) within the context of a “Massing” family. However, because ACs belong to categories other than Massing, they will be visible when the massing category is not visible. ACs can be joined to families/geometry belonging to the same category, even if those families are not part of the Mass family that hosts the AC.

Host Geometry – in Revit host geometry would typically be considered to be geometrical elements which can host other geometrical elements. For instance when a window is placed in a wall, the wall family is the “Host” for the Window Family. When building Window, Light Fixture, Air Terminal, etc. families the pre-defined template files contain an example piece of host geometry. In the case of “Face Based” families the host geometry is a generic extrusion element. In the case of a traditional curtain panel family or 2D profile, the host elements are the four reference planes. When constructing Curtain Panel By Points and Adaptive Components the host geometry will be special **Reference Points**. While these points are not representative of “real” geometry, in cases where they function as “hosts” they must be equated with their cousins: walls, extrusions reference planes, etc.

Hosting – the act of using a piece of Revit geometry to host another Revit family.

Workplane – the coordinate plane which geometry is hosted to. When creating almost all geometry in Revit it is hosted to a workplane. In Conceptual Massing and the Family Editor it is important to define which workplane is to be used. When working in a project environment workplanes are often automatically assigned.

Reference Point – a Revit reference element that represents a single point in space. Points are a datum element (similar to levels, grids and reference lines/planes); points follow rules similar to those followed by reference lines and planes. Points have an offset value that accepts either positive or negative distances. Reference points are typically hosted to a workplane defined by the environment, other points, reference lines/planes or geometry. Depending upon the context a point can be three different types (see illustration 1); Reference Point, Placement Point (Adaptive), Shape Handle Point (Adaptive). When building Adaptive Component Families

reference points are how you start your family, they are converted to “Placement Points” and define how the family is hosted/placed in a project/file when loaded into a file.

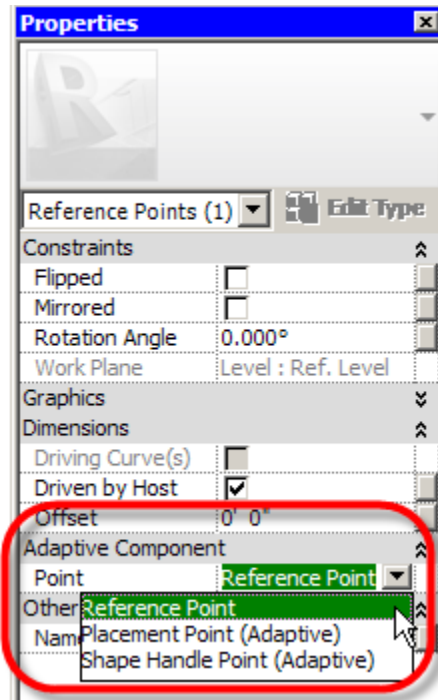

ill. 1 – Types of Points

Reporting Parameters – Are user defined parameters. Unlike typical Revit parameters, reporting parameters are not used to affect (drive) geometry or form. Reporting parameters are only useful when a dimension string is labeled with the parameter. Once a dimension string is labeled with a reporting parameter, the parameter provides feedback (reports) based on the elements the dimension string is constrained to. When a dimension string is attached to Host Geometry and labeled with a reporting parameter, the value of the parameter can be used in formulae to calculate the value of other geometrical parameters in the family, which in turn can drive geometry shape, size and form. Reporting parameters can also be Shared Parameters, which means they can be used to schedule information that would otherwise not have been possible to schedule in Revit.

Exercises

- I. **Basic Curtain Panel** – a simple curtain panel that explores point on point hosting & point orientation.

This exercise is meant to convey how Revit calculates how geometry should behave relative to the host condition. Both, curtain panels by pattern and adaptive components follow similar rules; the biggest difference between the two is that Curtain Panels integrate as part of a system, while Adaptive Components allow free association to just about any host.

If you extrude a piece of geometry in a curtain panel family using the default reference lines (see illustration 2) it will repeat quite nicely on a flat surface (see illustration 3). However on curved surfaces the result will be what is shown in illustration 4 and illustration 5. The geometry in illustration 4 may be the desired result, however a seamless surface on a curved form, similar to illustration 3, may be what is required (see illustration 6).

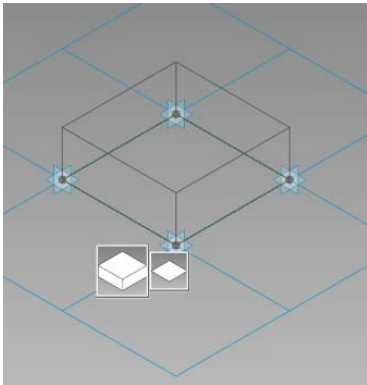

ill. 2

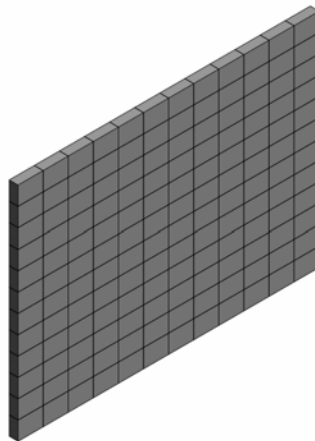

ill. 3

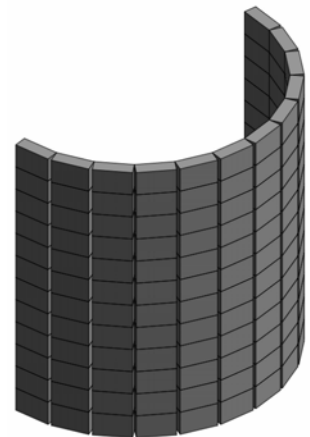

ill. 4

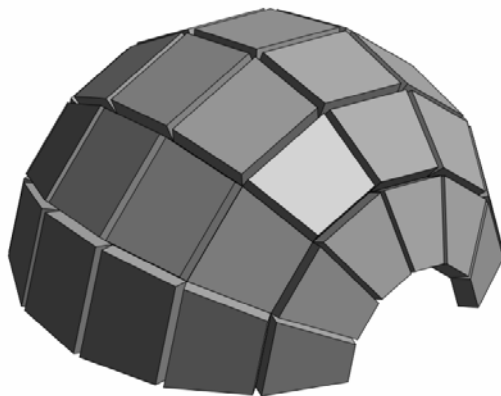

ill. 5

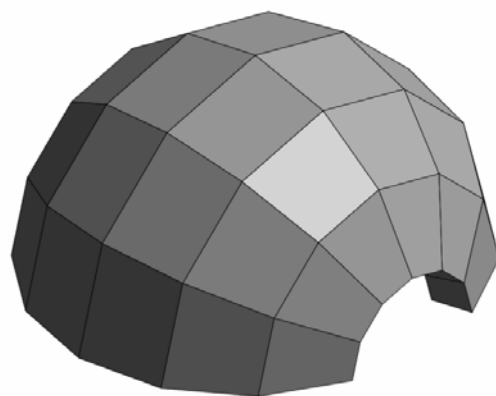

ill. 6

- 1) Open the file - **Armature.rfa**
- 2) In the Project Browser under Curtain Panels right click on the curtain panel family "**Exercise One**" and choose "edit".

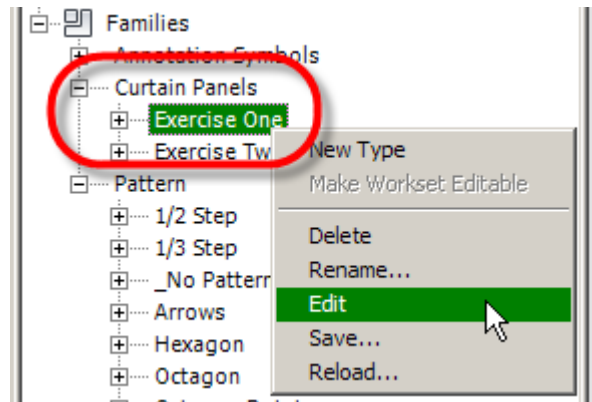

Fig. 1

When you open the family there are four **Adaptive Points** that are part of the **Curtain Panel By Points** template, they define the four corners of the **Rectangle Pattern**. Additionally two **Reference Points** have been added which are hosted to two of the corner points and offset from them.

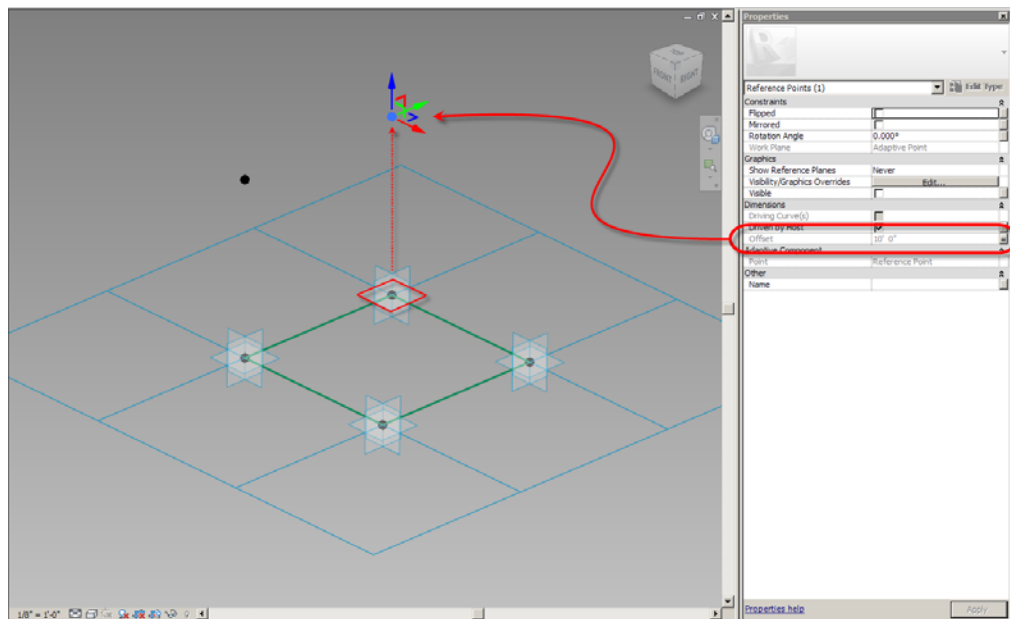



Fig. 2

- 3) Next the point tool  will be used to add one point to each of the two remaining corner points. When using the point tool it is critical to make sure to set the

workplane for each new point. In this case the workplane should be the XY reference plane defined by the corner point.

Set workplane for new point

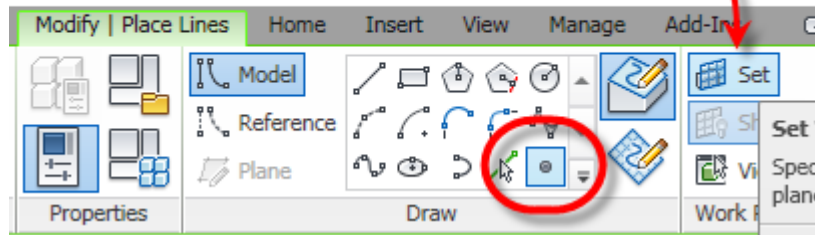

Fig. 3.1

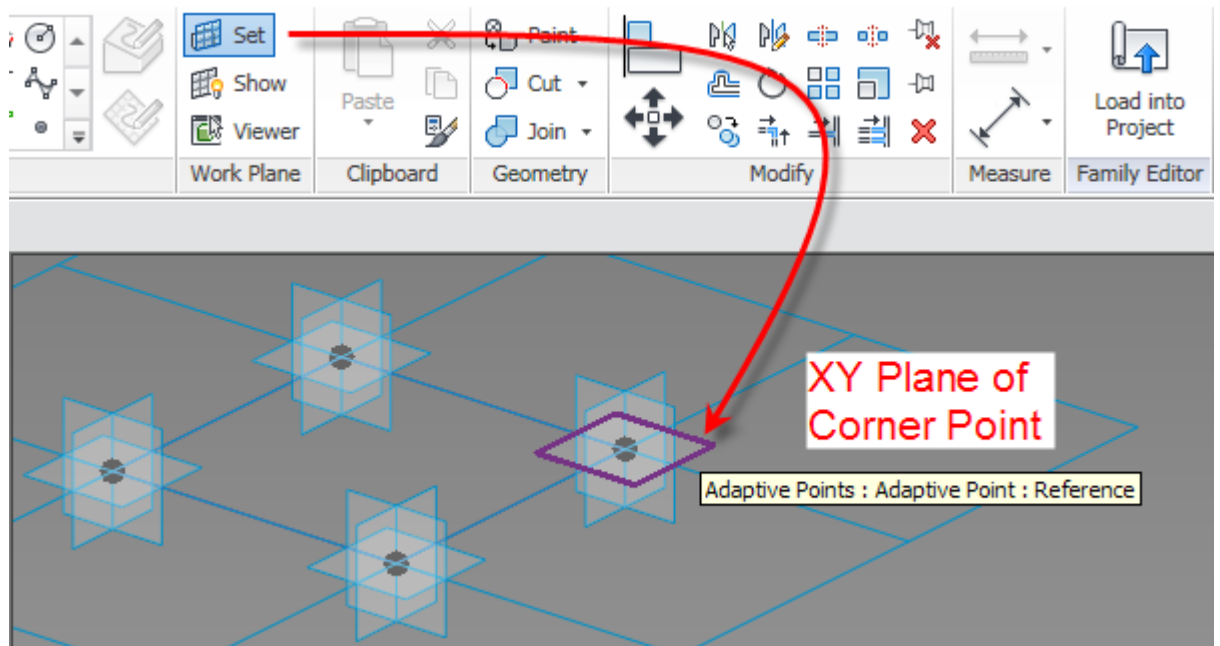

Fig. 3.2

Note: unlike Revit 2010, in 2011 you do not receive a warning about a point being placed on a point. In this case a reference point is being placed on top of an Adaptive Point, since they are considered to be two different types of objects Revit does not generate a duplicate element warning.

- Use a selection box and the filter tool to select the two reference points that were added in the previous step.

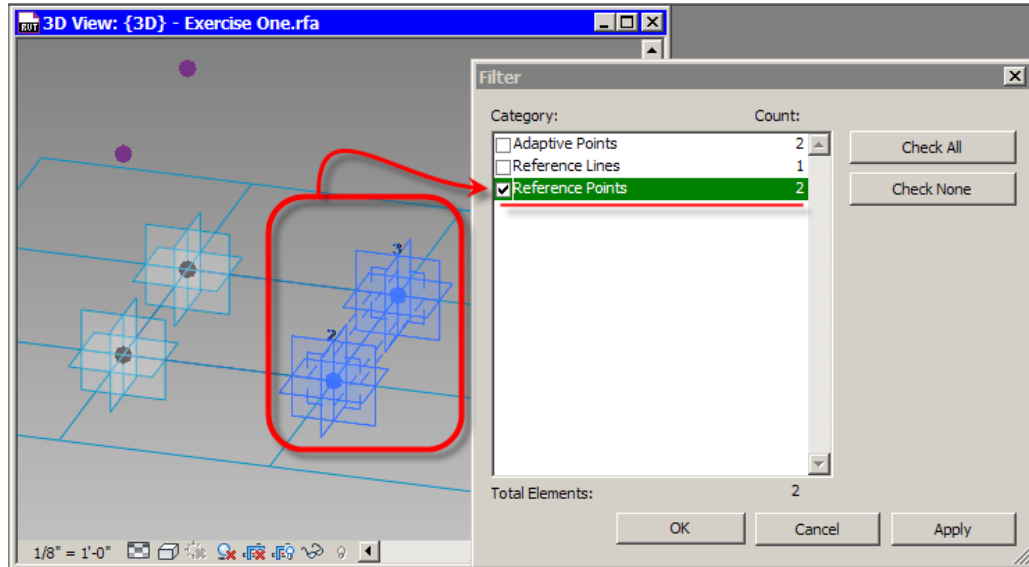

Fig. 4

- Use the properties palette to link the “Offset” property of the two points to the “Offset” parameter (pre-defined in the family).

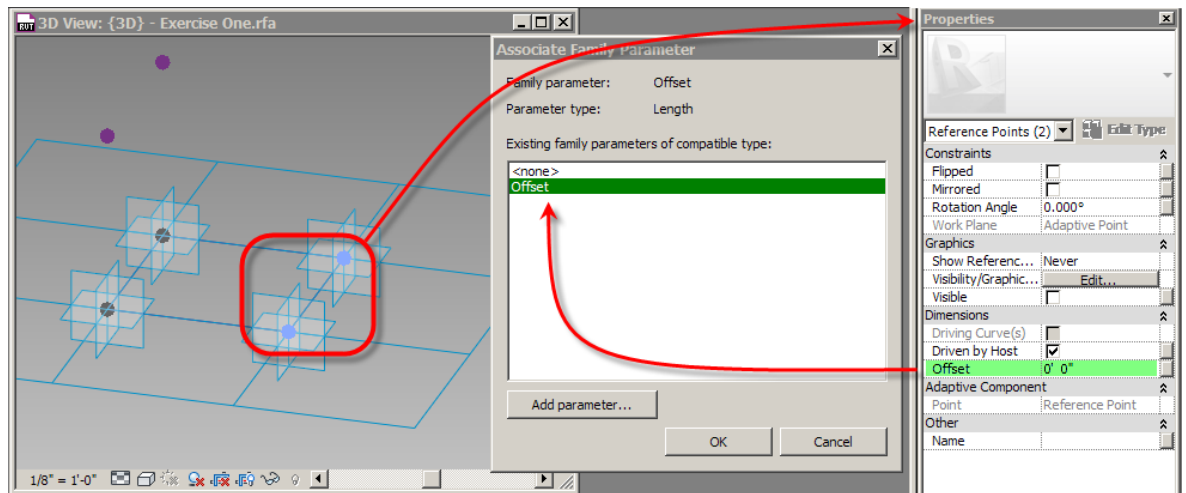

Fig. 5

Key Concept - Offsets are helpful because they will accept negative or positive values more easily than moving the point using a labeled dimension(s). Labeled dimensions also require consideration of the dimension’s workplane; offsets are relative to the workplane the point is hosted to. It is important to note that the only way to “find” offsets is to select a point and check its property; there are no visual indicators to show the dimensional relationships.

- 6) Click and drag one of the Adaptive (Corner) Points; “click and drag” allows the point to move vertically relative to its workplane (the **Tile Pattern Grid**). Release the mouse button to stop dragging. To reset points to the pattern, select the pattern and click on the “**Reset to Grid**” button in the Options Bar

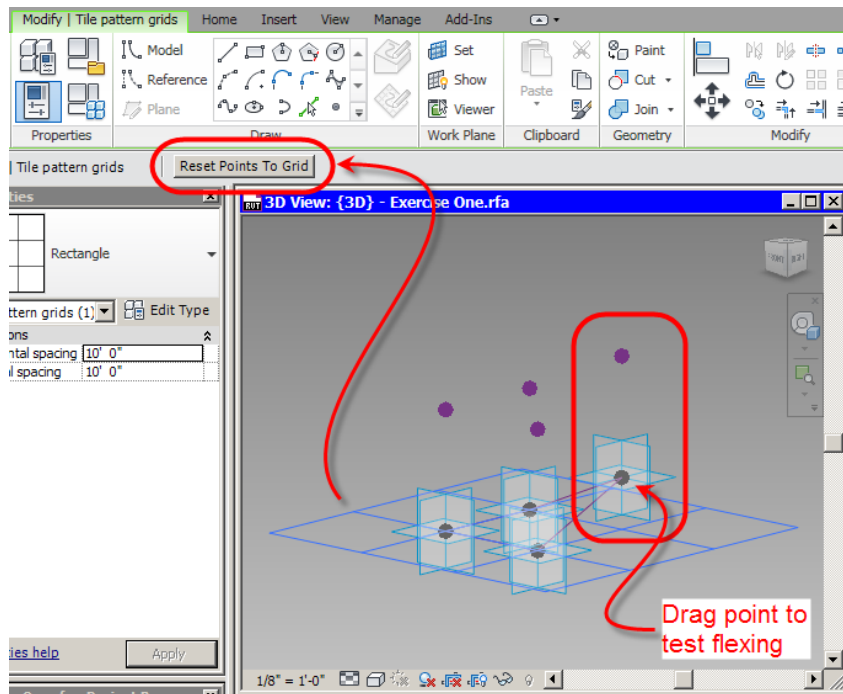

Fig. 6

Key Concept - an important part to building Adaptive Components and Curtain Panels is **flexing** the host points, in Curtain Panels these points are pre-defined and can be moved vertically quite easily. In Adaptive Components the user defines their own points, these points can also be moved around. In both cases it is important to move and flex these points to assure the whole rig works and changes as anticipated. In Curtain Panels by Pattern, the blue grid is a visual framework to aid in building the family, it does not provide geometry that can be snapped to or used as a host element.

- 7) Activate the **Reference Line** tool, check the “**3D Snapping**” box in the Option bar, verify the “Chain” option is checked. Draw a rectangular chain of lines between the four offset points. When the start point is reached use “escape” to stop drawing lines.

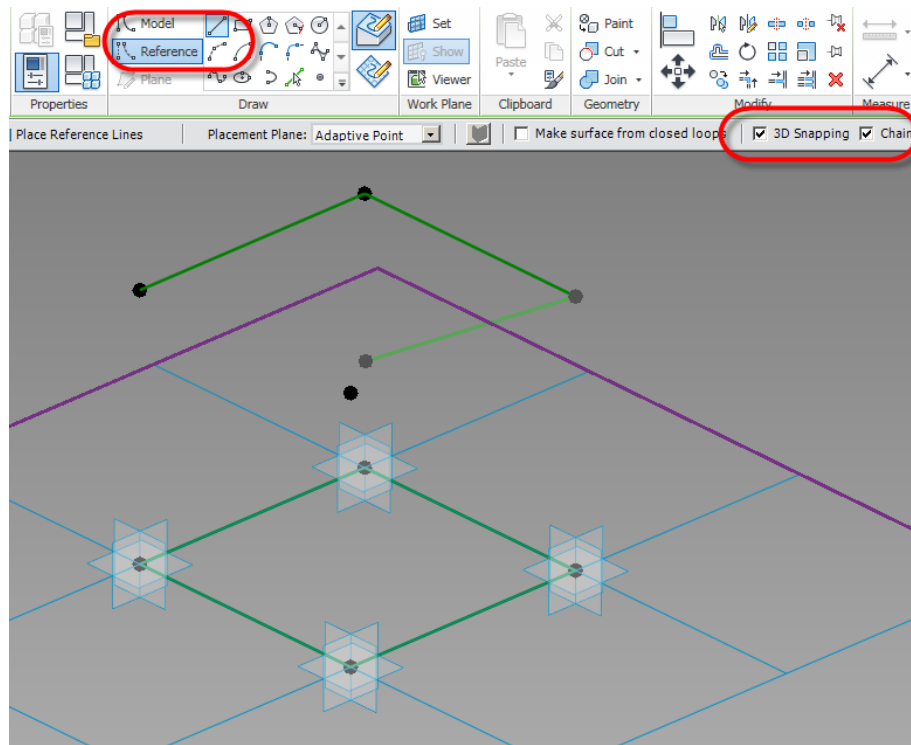

Fig. 7

Key Concept(s) - Reference lines are critical to building rigs because they can be used to create form elements but they are not consumed by the creation of the form element. This can be particularly important when building parametric rigs that flex with geometry changes. It is possible to define and control the behavior of the reference elements, then attach or “drape” geometry on the reference elements. Alternately the reference elements can be used to define geometry; however any parametric behavior that has previously been defined is retained, through the form creation process.

3D Snapping is important too! 3D Snapping effectively overrides any “workplane” and tells Revit it should compute the location of the element based on the snap points picked while drawing the element. This is a very powerful feature as it frees the user from the restrictions of an entirely workplane based editor.

- 8) Select the two chains of reference lines (top & bottom) and click on the “Create Form” button to create a simple box.

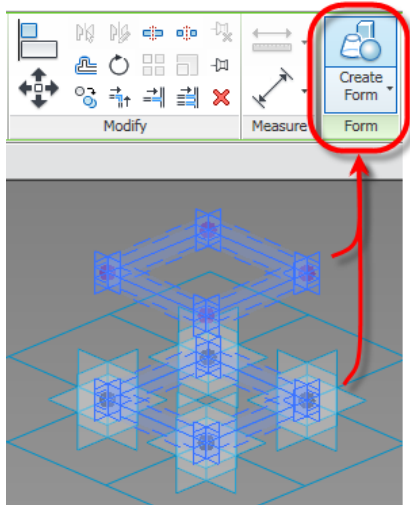

Fig. 8.1

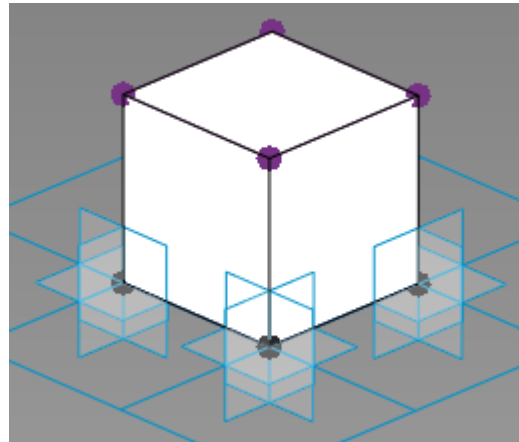
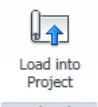

Fig. 8.2

- 9) Click on the “Load into Project” button  to load the Curtain Panel Family into the file. Choose to overwrite the family that is already loaded.
- 10) Select the Divided surface and in the Type Selector choose the family that was just loaded “Exercise One”.

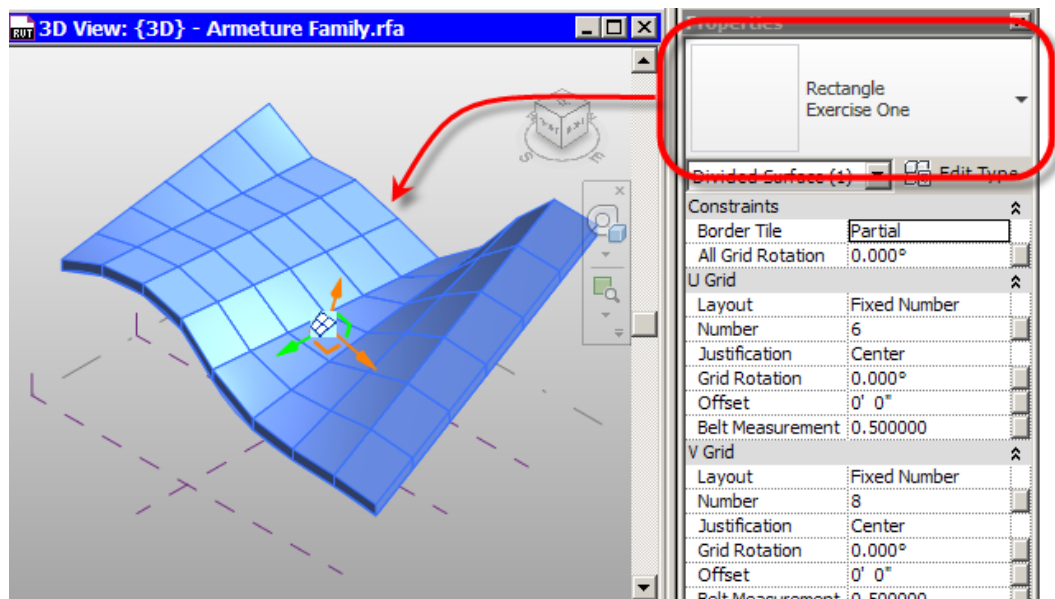

Fig. 9

Optional Steps (dependent on class skill level & time check):

- 11) Use Tile Windows (keyboard shortcut WT) to tile the family and the armature file, and Zoom to fit the two windows.
- 12) Using a selection box and the Filter tool select the four corner points of the pattern (Adaptive Points).

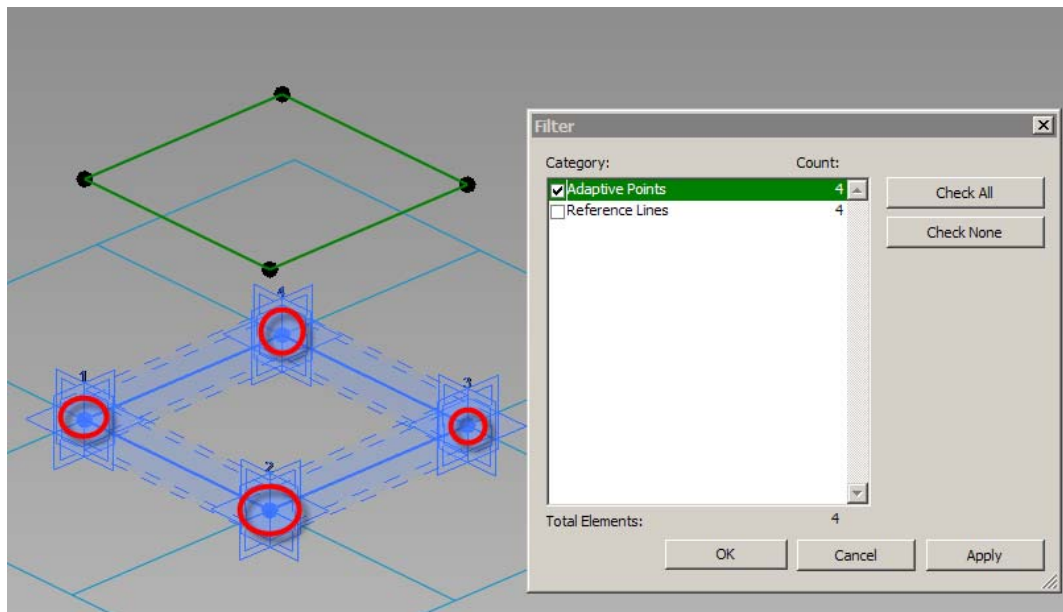

Fig. 10

- 13) Change the Property of the four reference points named "Orientation" from "Auto Calculate"-calculate" to "Vertical in Family".

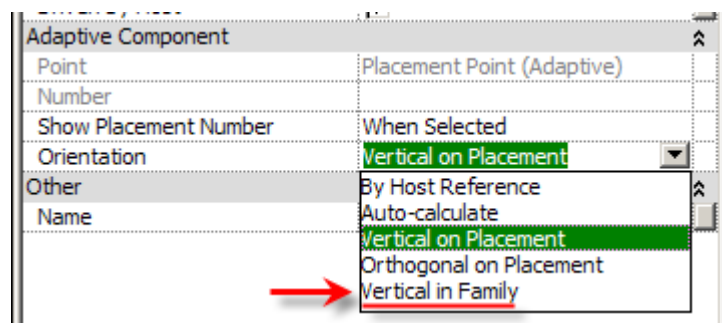
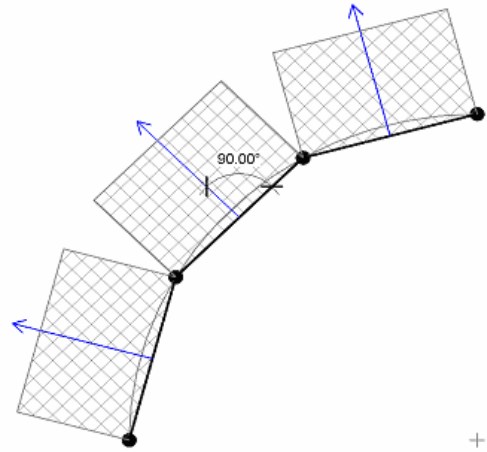

Fig. 11

- 14) Load the Exercise One into the Armeture family again.

Key Concept: If geometry is created with only the reference lines defined in the default template, the geometry is extruded and behaves relative to the plane defined by the points (see illustration 7).

By adding points offset from the corner points the geometry is based on the orientation of the corner points (see illustration 8). The result is a seamless panel (see illustration 9).



ill. 7

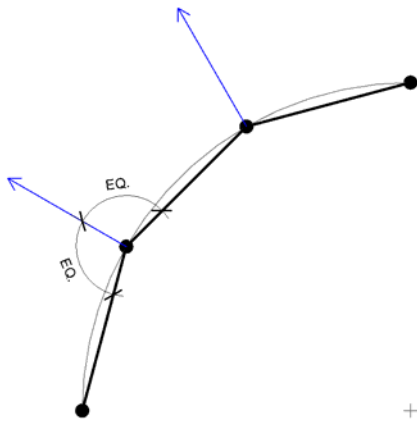

ill. 8

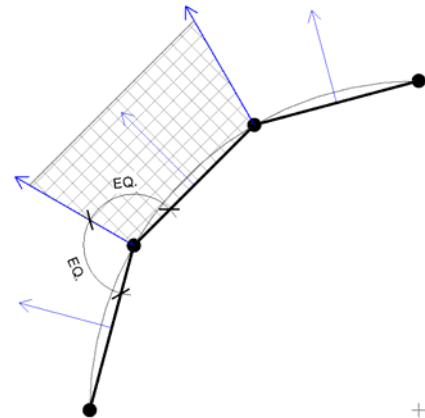

ill. 9

Using “Vertical in Family” ends up in a geometrical result similar to what the default setting which is “auto-calculate”. Vertical in family orients the points relative to the family itself (see illustrations 10 & 11).

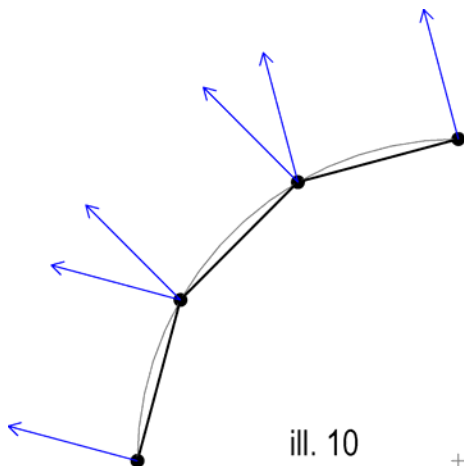

ill. 10

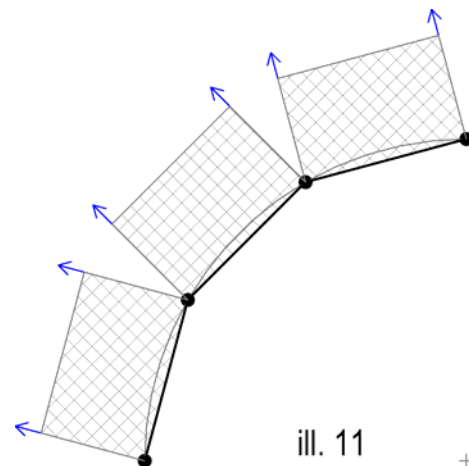

ill. 11

Changing the point's orientation setting to other options allows for more refined control of the geometry, depending upon the desired result and context, for instance "Vertical in Project" (see illustration 12).

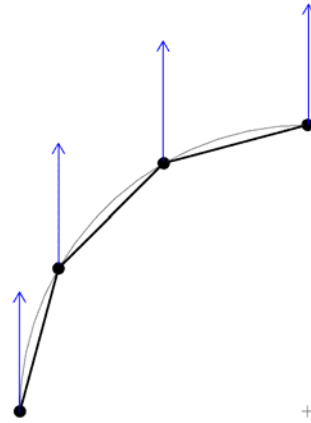

ill. 12

II. **Curtain Panel Frame** – simple curtain panel using hosted points and profiles to create a frame.

- 1) From the project browser right click on the curtain panel family “**Exercise Two**” and choose “Edit”.

Note: This family is similar to the one just constructed, except vertical reference lines and a hosted point with a profile have been added, the form and one of the horizontal lines have been removed to simplify the process. Additional parameters have been added too.

- 2) **Key Concept** - The first step will be to create a new Dimension String. When working with Panels or Adaptive Components the **Workplane** of the dimension string is important. Placing the dimension string on the wrong workplane will result in constraints breaking.

Use the “Set” button to set the **Active Workplane** to the XY plane defined by the reference line with the hosted point and profile.

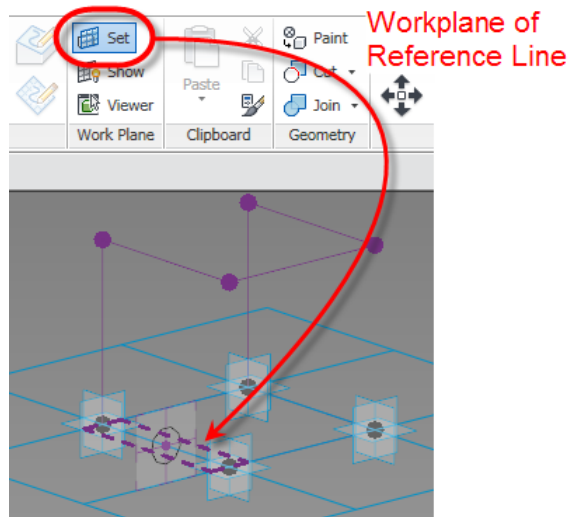

Fig. 12

Note: You may need to use “Tab” to select the proper reference plane to set to the active workplane.

- 3) **Key Concept** – the dimension string **must** be to the two points, not the reference planes defined by the points and not the other reference lines. This is critical to the behavior of the dimension string as a constraint.

Use the dimension tool to dimension between the two points **not** the reference planes or lines.

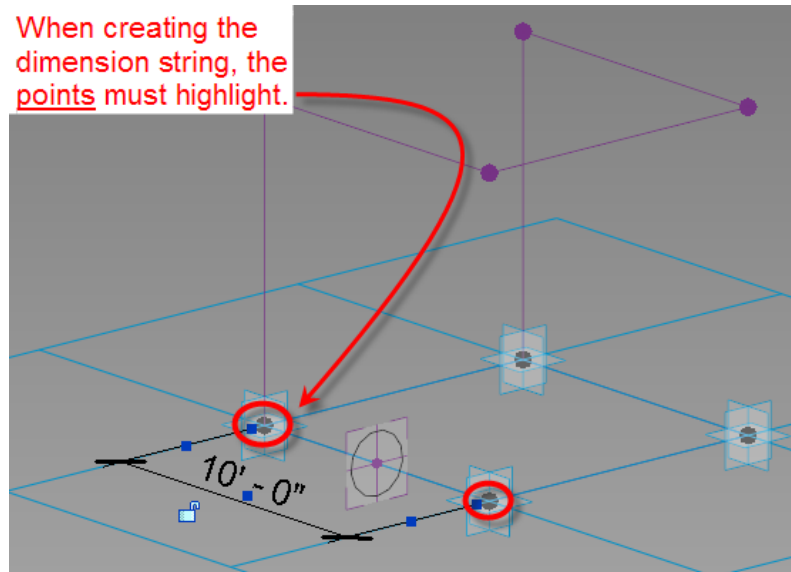

Fig. 13

- 4) Label the dimension with a new parameter:
Name: **Dr** (*Distance Reporting*)
Group the Parameter Under: **Constraints**
Set to "**Instance**"
Check the box for "**Reporting**"

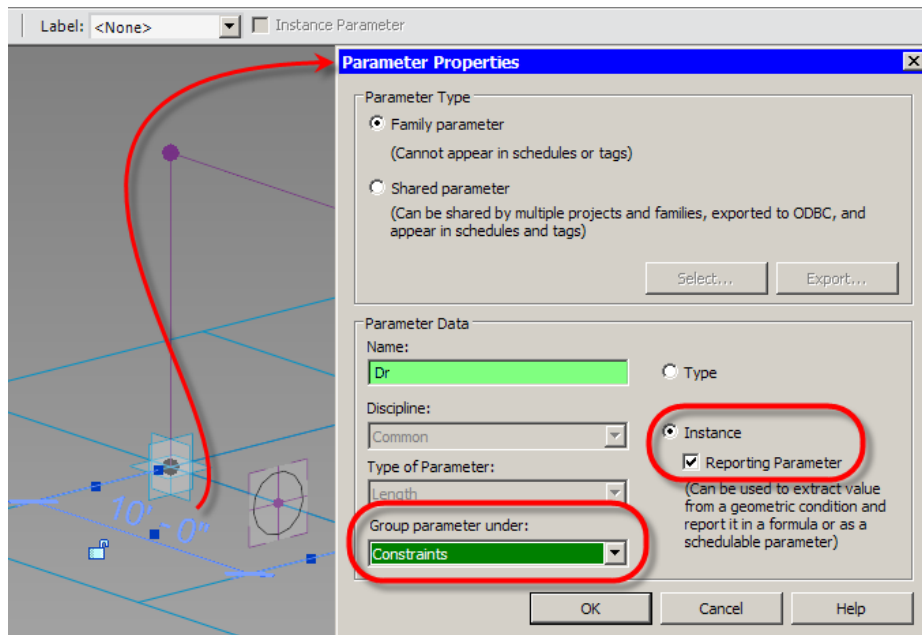

Fig. 14

Key Concept - Reporting Parameters are fantastic tools! If you are simply interested in information to put in a schedule or tag, then you can dimension to anything you want to and make it a shared parameter¹. However, if you want to use the reported value to “do something” i.e. affect geometry by way of formulae, then you must dimension between **host geometry**. In this case the two corner points which help to define the curtain panel.

¹ For more on using Shared Parameters in conjunction with Reporting Parameters, see this post: <http://buildz.blogspot.com/2010/04/adding-reporting-parameters-to-curtain.html>

- 5) Go to the Types dialog, in the formula field for parameter “R” enter: **Dr / 20**

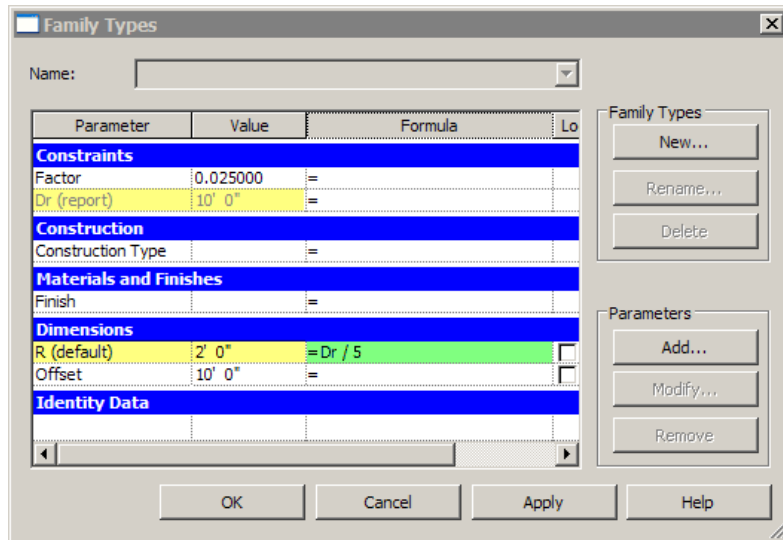

Fig. 15 (follow instructions, ignore values in the image)

Note: there also is a predefined parameter named “Factor” in the family. This can be used in lieu of the “5”. The advantage of using a parameter allows quick adjustment once the family is placed in a Divided Surface.

- 6) Select the Circular profile and all of the reference lines except the “left bottom”. Click on create form to create a sweep.

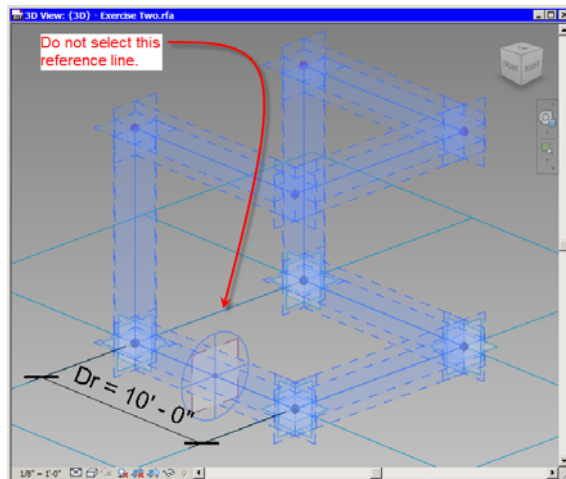

Fig. 16.1

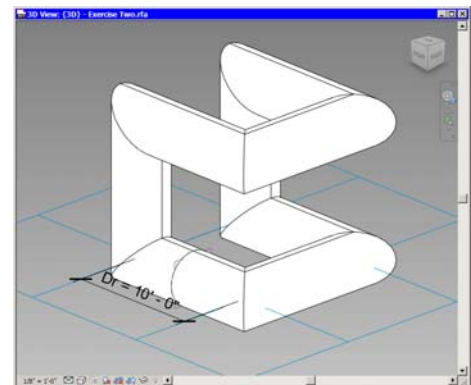

Fig. 16.2

Key Concept: the circular profile on the hosted point is actually a nested generic family. Generic families with model lines can be used as profiles, if you want to use this technique make sure to un-check the “Always Vertical” property (on by default) in the Generic Family template.

- 7) Load the family into the Armeture family.
- 8) Apply the Exercise Two family to the Dome Armeture.

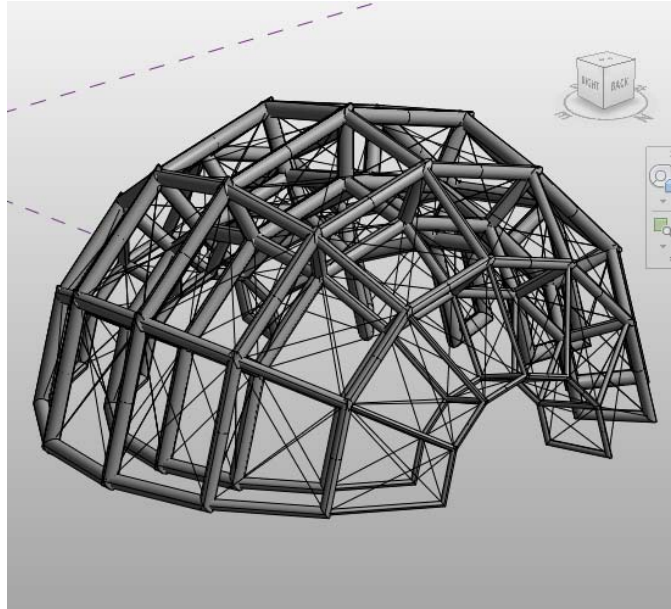

Fig. 17

Note: *The profile's radius adjusts based on the length of the side of the panel to which the Reporting Parameter was applied.*

III. **Adaptive Components** – this exercise looks at how Adaptive Components are very similar to Panels by Pattern, the key difference is the modeler defines how the family hosts and therefore Point Orientation is critical.

- 1) Orbit around the mass from the last exercise so that you can see the side without a frame at the bottom.
- 2) Select the mass, and in the ribbon, click on the “Component” button to hide the Curtain Panels and show only the divided surface. Click on the “Surface” button to make the surface visible.

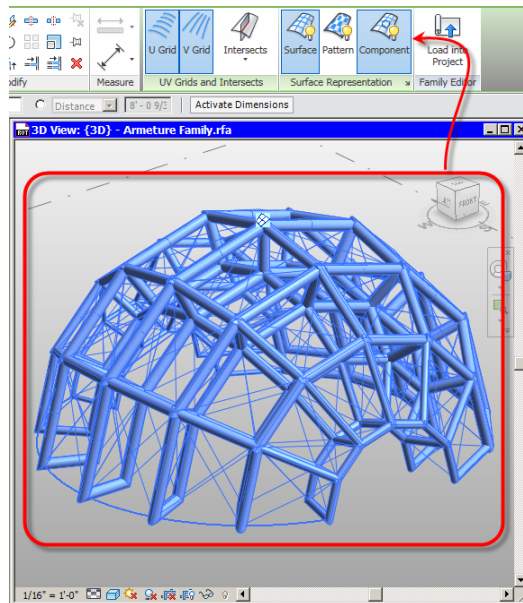

Fig. 18

Note: This “graphic override” is internal to the family and persists when the family is placed in another family or project. It is unique and unlike Visibility & Graphic overrides.

- From the project browser drag the Default type of Exercise Two into the canvas. Click on the four bottom nodes in order from the edge to the middle. If the panel is facing in the wrong direction, use the "Flip" property to re-orient it.

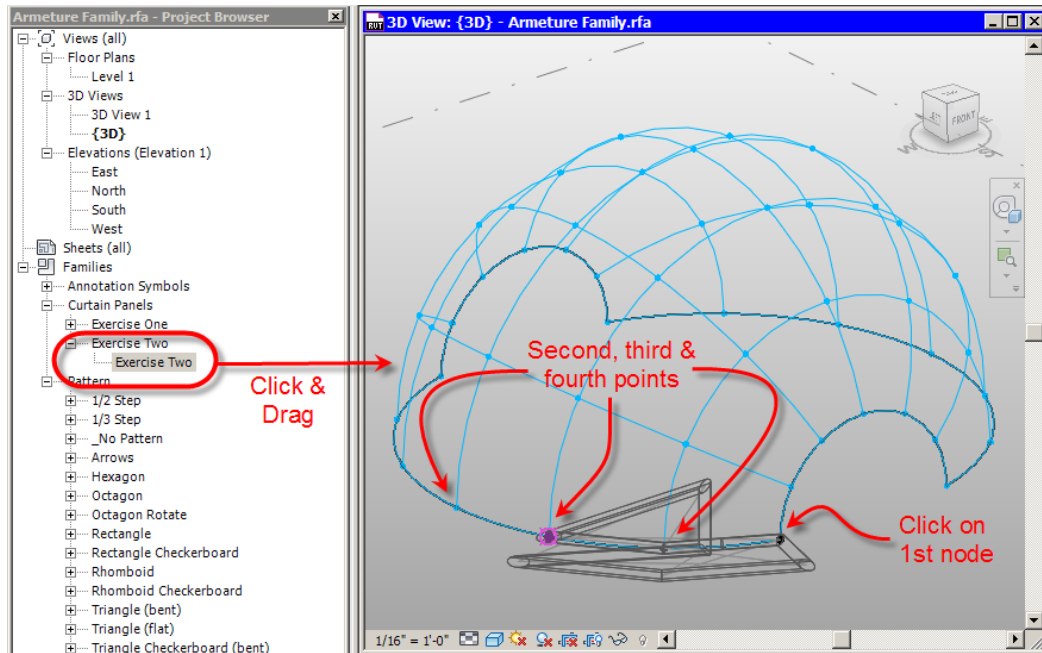
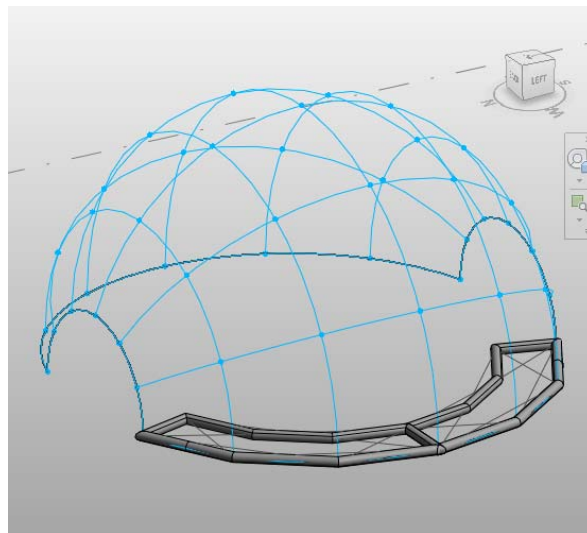

Fig. 19

Key Concept – The curtain panel has just been used as an **Adaptive Component** (AC). Even though the family was built using a Curtain Panel template, because it uses Reference Points as the host elements, it can be dragged into canvas and used as an AC.



The problem with using a Curtain Panel as an AC is that the behavior is based on the assumption that the family is used as a curtain panel, for instance if the panel is strung across the example form like a truss, it does not project orthogonally relative to the horizontal workplane, rather it projects at the calculated normal, which is the desired behavior in the panel family.

Fig. 20

- 4) In the Project Browser under Generic Families->Adaptive Components right click and click to edit the “Exercise Three” family.
- 5) This family is effectively the curtain panel “un-folded”. Two more points and reference lines need to be added to complete the family.

Note: The “workplane” for this point was not specifically defined as it will be converted into an adaptive point in the next step.

- 6) Place a new point aligned with the row of three points with their reference planes visible. Select the point and click on the “Make Adaptive” button in the ribbon.

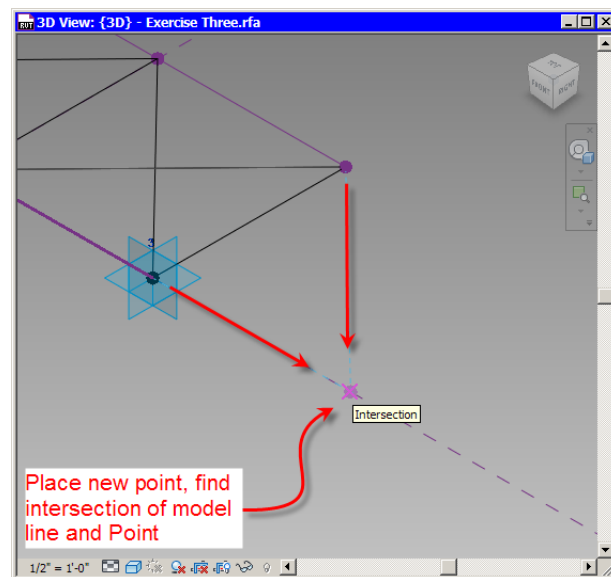
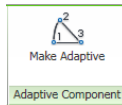

Fig. 21

Key Concept – “Make Adaptive” allows you to define your own host points, you can have as few as one, or as many as you like. Note the changes to the properties of the point, and the change in graphic representation. Each point is numbered; the numbers indicate the order in which the points will be placed when a user places the AC in the project environment. The numbering is a property of each point and can be modified from the properties palette.

Note: Once an adaptive component is loaded and placed it is not possible to delete or add host points.

- 7) Add a new reference point, hosted to to the XZ reference plane of the new Adaptive Point. Link the new point's Offset property to the pre-defined parameter "H".

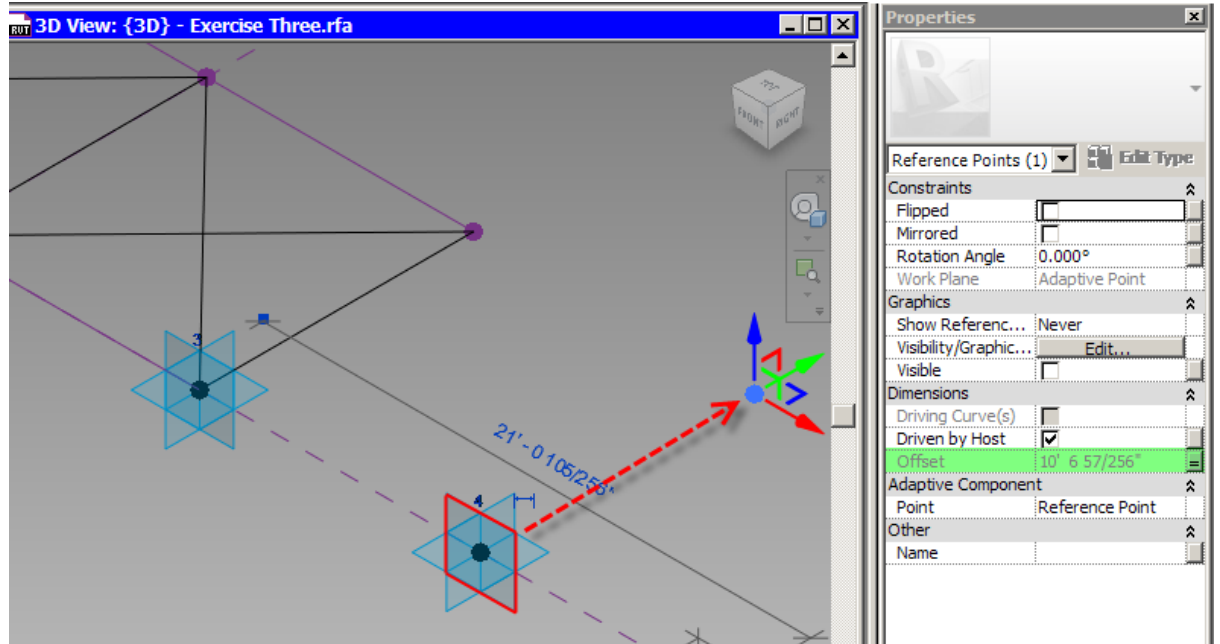

Fig. 22

- 8) Using 3D Snapping draw three Reference Lines counter clockwise from Adaptive Point 3, to the third hosted point.

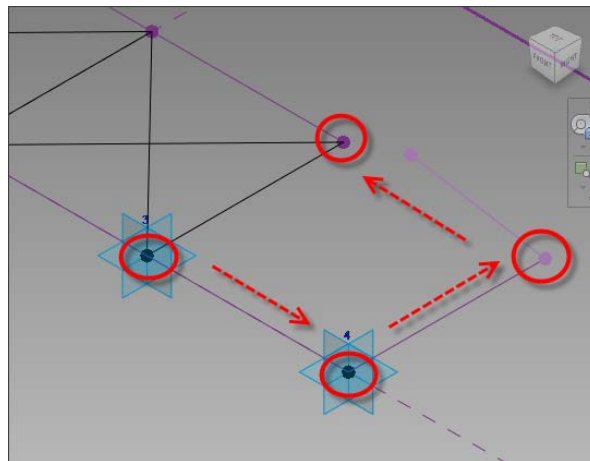

Fig. 23

- 9) Using 3D Snapping draw two model lines set to the Subcategory "Tension Members".

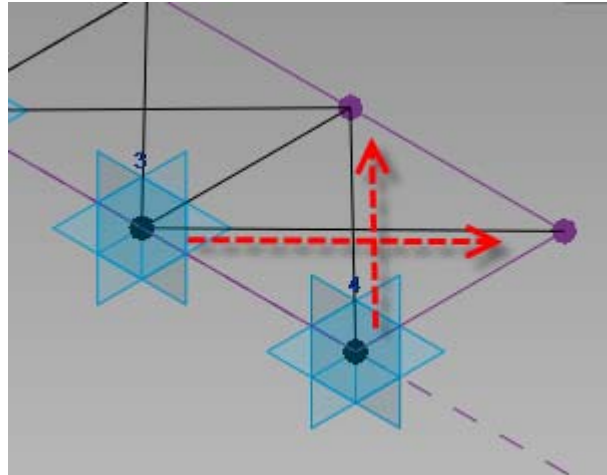

Fig. 24

- 10) Select all of the reference lines using the filter tool (9 Elements), and click on the "Create Form" button.

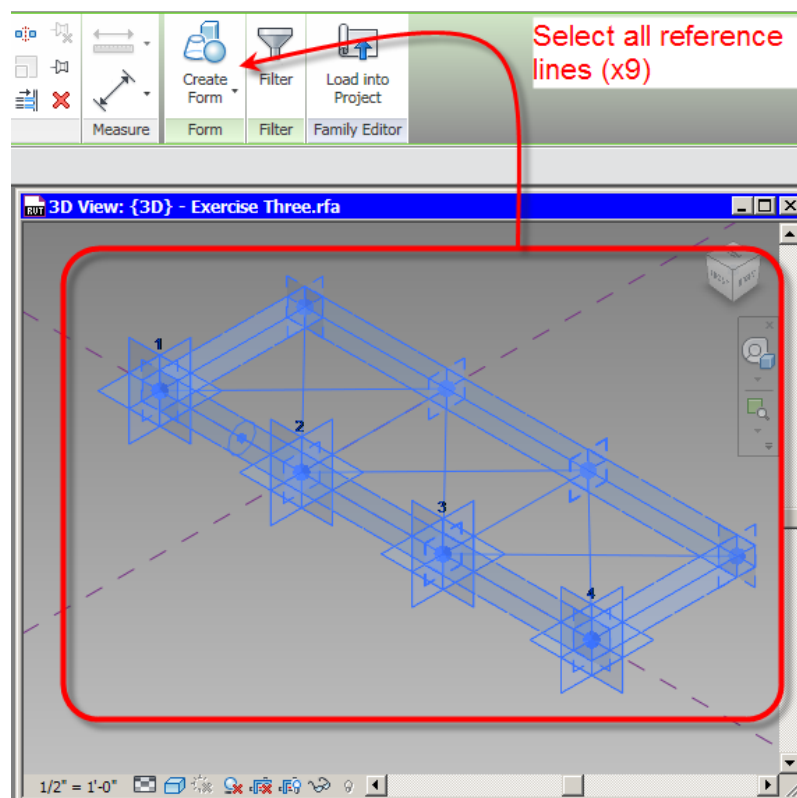

Fig. 25

- 11) Load the family into the Armature file and overwrite the loaded family.
- 12) Select the third dome mass in the Armature family. In the ribbon click on the “Surface Representation Button”. In the dialog un-check the box for “Original Surface”, check the box for “Nodes”. Click Ok.

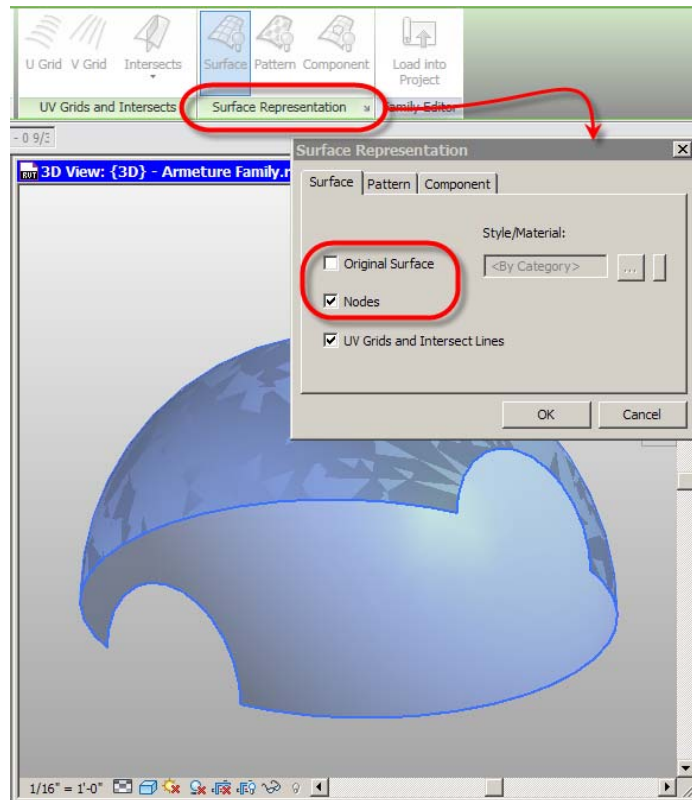

Fig. 26

Key Concept – Nodes are not on by default when working with divided surfaces. They must be manually turned on. Once turned on they can be used to snap to, to place families or create geometry.

- 13) Drag the Exercise Three family from the project browser and snap to the nodes of the form, following open curve of the dome.

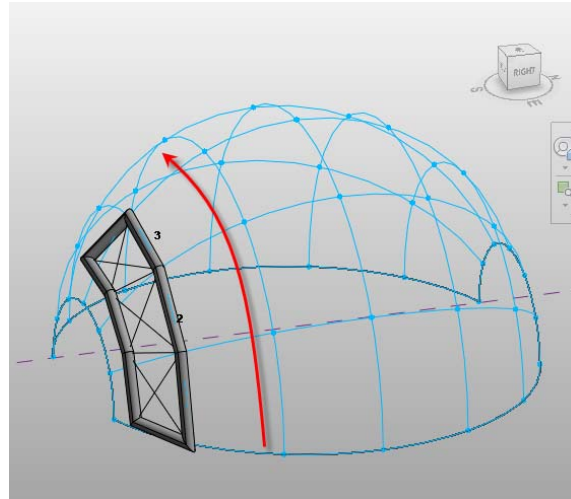

Fig. 27

- 14) Go back to the Exercise Three family. Select all four Adaptive Points using the filter tool. Set the Orientation property to "Vertical In Family". Reload the family into the Armature family.

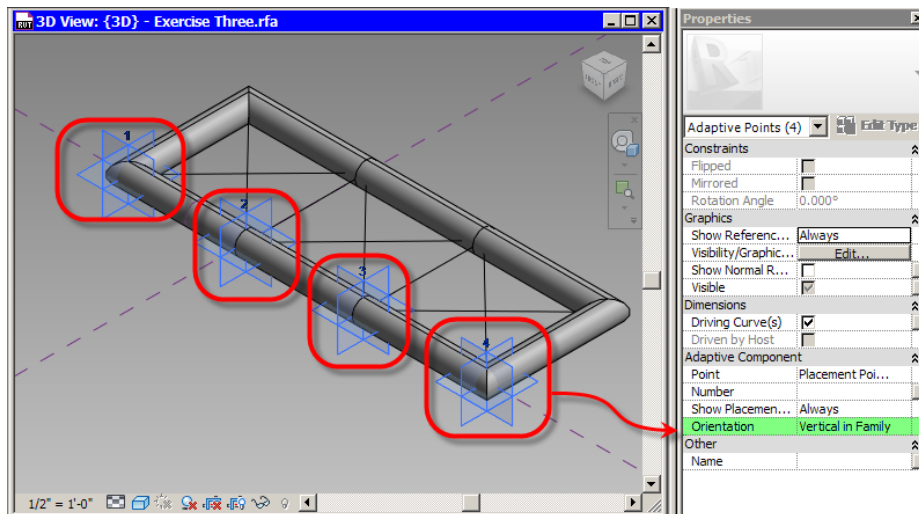

Fig. 28

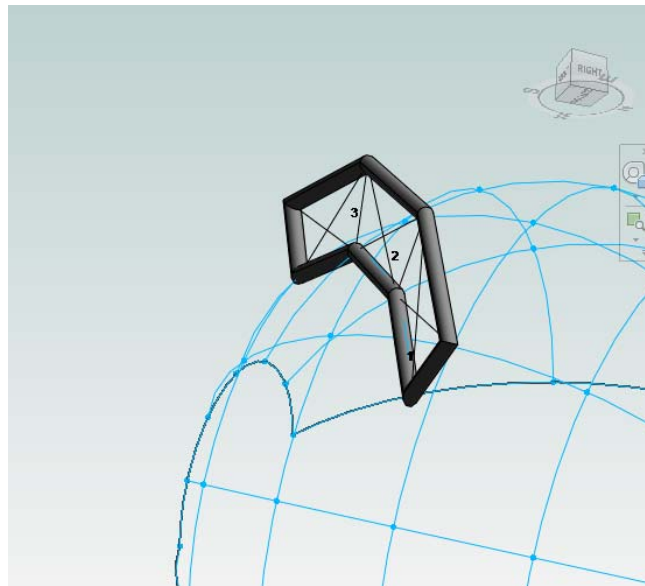

Fig. 29

Key Concept – Changing the Orientation property once again affects how the family behaves in the project environment. In this case using “Vertical In Family” it used the Family’s orientation to determine the direction of the geometry. Note that while the family stands up “straight” in the project, the family is built “sideways” much in the way face based families must often be built “sideways” relative to the views in the family.

Key Points to Remember:

1. Workplanes – always think about the workplane used when creating geometry.
2. Flex Adaptive Points – just like any family, flex everything to make sure it works correctly. Finding problems in rigs before increasing complexity or adding geometry is critical.
3. Use reference point's offset parameter
4. Be aware of orientation.
5. Use 3D snapping to create reference lines to build a flexible rig.
6. Create geometry last.
7. Reporting parameters must be used between adaptive/host points to flex geometry based on the dimensions between the points.